

# Double vane pumps type PFED

fixed displacement

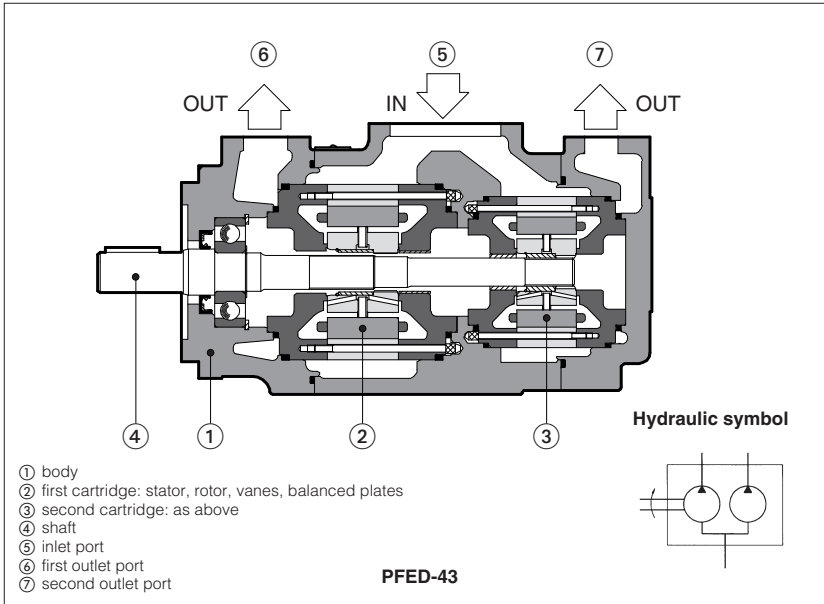

PFED are fixed displacement double vane pumps (②③) composed by two cartridges of pumps type PFE (see tab. A005) assembled in a main body having one inlet port (⑤) and two outlet ports (⑥⑦).

PFED-43 are composed by one cartridge of PFE-41 and one cartridge of PFE-31. PFED-54 are composed by one cartridge of PFE-51 and one cartridge of PFE-41.

Suitable for hydraulic oils according to DIN 51524...535 or synthetic fluids having similar lubricating characteristics.

These pumps can be assembled, as second element, with PFE-4 and PFE-5 to obtain triple pumps, see tab A190.

Mounting according to SAE J744. Easy installation as inlet and outlet ports can be assembled in any of four relative positions. Easy maintenance as pumping cartridge can be replaced in a few minutes.

Wide variety of displacements: from 29+16 up to 150+85 cm<sup>3</sup>/rev. Max pressure up to 210 bar.

## 1 MODEL CODE

<b>PFED</b>	-	<b>43</b>	<b>045</b>	/	<b>022</b>	/	<b>1</b>	<b>D</b>	<b>TA</b>	<b>**</b>	<b>/ *</b>
Fixed displacement double vane pump										Seals material: omit for NBR (mineral oil & water glycol) <b>PE</b> = FPM Series number	
Size of cartridges: <b>43</b> = composed by: one cartridge of PFE-41 + one cartridge of PFE-31 <b>54</b> = composed by: one cartridge of PFE-51 + one cartridge of PFE-41										Ports orientation, see section 4	
Displacement of first element [cm <sup>3</sup> /rev], see section 3										Direction of rotation (as viewed at the shaft end): <b>D</b> = clockwise (supplied standard if not otherwise specified) <b>S</b> = counterclockwise Note: PFED are not reversible	
Displacement of second element [cm <sup>3</sup> /rev], see section 3										Drive shaft, see section 6 and 7: cylindrical, keyed <b>1</b> = supplied standard if not otherwise specified <b>2</b> = according to ISO/DIN 3019 <b>3</b> = for high torque applications splined <b>5</b> = for PFED-43: according to SAE B 13T 16/32 DP (13 teeth) for PFED-54: according to SAE C 14T 12/24 DP (14 teeth) <b>6</b> = (only for PFED-43) = according to SAE C 14T 12/24 DP (14 teeth) <b>7</b> = (only for PFED-43) = similar to shaft type 6. It is used when PFED-43 is the last element of a multiple pump	

## 2 MAIN CHARACTERISTICS OF DOUBLE VANE PUMPS TYPE PFED

Installation position	Any position.
Loads on the shaft	Axial and radial loads are not allowed on the shaft. The coupling should be sized to absorb the peak horsepower developed.
Ambient temperature	from -20°C to +70°C
Fluid	Hydraulic oil as per DIN 51524...535; for other fluids see section 1
Recommended viscosity	max at cold start 800 mm <sup>2</sup> /s max at full power 100 mm <sup>2</sup> /s during operation 24 mm <sup>2</sup> /s min at full power 10 mm <sup>2</sup> /s
Fluid contamination class	ISO 4401 class 21/19/16 NAS 1638 class 10 (filters at 25 μm value with β <sub>25</sub> ≥ 75 recommended)
Fluid temperature	-20°C +60°C    -20°C +50°C (water glycol)    -20°C +80°C (/PE seals)
Recommended suction line pressure	from -0,5 to 1,5 bar for speed up to 1800 rpm; from 0 to +1,5 bar for speed over 1800 rpm

3 OPERATING CHARACTERISTICS at 1450 rpm with hydraulic oil having viscosity of 24 mm<sup>2</sup>/sec and 40°C

Model	7 bar				70 bar				140 bar				210 bar				Speed range min/max rpm
	1°flow		2°flow		1°flow		2°flow		1°flow		2°flow		1°flow		2°flow		
	l/min	Kw	l/min	Kw	l/min	Kw	l/min	Kw	l/min	Kw	l/min	Kw	l/min	Kw	l/min	Kw	
<b>PFED-43</b>																	
PFED-43 029/016	41	0,8	23	0,5	39	5,5	21	3	37	10	19	5	34	14	16	6,5	
PFED-43 029/022	41	0,8	30	0,6	39	5,5	28	4	37	10	26	7	34	14	23	10	
PFED-43 029/028	41	0,8	40	0,8	39	5,5	38	5,5	37	10	36	10	34	14	33	14	
PFED-43 037/016	52	1	23	0,5	50	7	21	3	48	12,5	19	5	45	18	16	6,5	
PFED-43 037/022	52	1	30	0,6	50	7	28	4	48	12,5	26	7	45	18	23	10	
PFED-43 037/028	52	1	40	0,8	50	7	38	5,5	48	12,5	36	10	45	18	33	14	
PFED-43 037/036	52	1	51	1	50	7	49	7	48	12,5	46	12,5	45	18	43	18	
PFED-43 045/016	64	1,3	23	0,5	62	8,5	21	3	60	16	19	5	57	24	16	6,5	
PFED-43 045/022	64	1,3	30	0,6	62	8,5	28	4	60	16	26	7	57	24	23	10	
PFED-43 045/028	64	1,3	40	0,8	62	8,5	38	5,5	60	16	36	10	57	24	33	14	
PFED-43 045/036	64	1,3	51	1	62	8,5	49	7	60	16	46	12,5	57	24	43	18	
PFED-43 045/044	64	1,3	63	1,3	62	8,5	61	8	60	16	58	15,5	57	24	55	23	
PFED-43 056/016	80	1,6	23	0,5	78	11	21	3	75	21	19	5	72	30	16	6,5	
PFED-43 056/022	80	1,6	30	0,6	78	11	28	4	75	21	26	7	72	30	23	10	
PFED-43 056/028	80	1,6	40	0,8	78	11	38	5,5	75	21	36	10	72	30	33	14	
PFED-43 056/036	80	1,6	51	1	78	11	49	7	75	21	46	12,5	72	30	43	18	
PFED-43 056/044	80	1,7	63	1,3	78	11	61	8	75	21	58	15,5	72	30	55	23	
PFED-43 070/016	101	2	23	0,5	98	13,5	21	3	95	26	19	5	91	37	16	6,5	
PFED-43 070/022	101	2	30	0,6	98	13,5	28	4	95	26	26	7	91	37	25	10	
PFED-43 070/028	101	2	40	0,8	98	13,5	38	5,5	95	26	36	10	91	37	33	14	
PFED-43 070/036	101	2	51	1	98	13,5	49	7	95	26	46	12,5	91	37	43	18	
PFED-43 070/044	101	2	63	1,3	98	13,5	61	8	95	26	58	15,5	91	37	55	23	
PFED-43 085/016	124	2,4	23	0,5	121	16	21	3	118	32	19	5	114	46	16	6,5	
PFED-43 085/022	124	2,4	30	0,6	121	16	28	4	118	32	26	7	114	46	23	10	
PFED-43 085/028	124	2,4	40	0,8	121	16	38	5,5	118	32	36	10	114	46	33	14	
PFED-43 085/036	124	2,4	51	1	121	16	49	7	118	32	46	12,5	114	46	43	18	
PFED-43 085/044	124	2,4	63	1,3	121	16	61	8	118	32	58	15,5	114	46	55	23	
<b>PFED-54</b>																	
PFED-54 090/029	128	2,7	41	0,8	124	17	39	5,5	119	33	37	10	114	48	34	14	
PFED-54 090/037	128	2,7	52	1	124	17	50	7	119	33	48	12,5	114	48	45	18	
PFED-54 090/045	128	2,7	64	1,3	124	17	62	8,5	119	33	60	16	114	48	57	24	
PFED-54 090/056	128	2,7	80	1,6	124	17	78	11	119	33	75	21	114	48	72	30	
PFED-54 090/070	128	2,7	101	2	124	17	98	13,5	119	33	95	26	114	48	91	37	
PFED-54 090/085	128	2,7	124	2,4	124	17	121	16	119	33	118	32	114	48	114	46	
PFED-54 110/029	157	3,2	41	0,8	152	21	39	5,5	147	40	37	10	141	58	34	14	
PFED-54 110/037	157	3,2	52	1	152	21	50	7	147	40	48	12,5	141	58	45	18	
PFED-54 110/045	157	3,2	64	1,3	152	21	62	8,5	147	40	60	16	141	58	57	24	
PFED-54 110/056	157	3,2	80	1,6	152	21	78	11	147	40	75	21	141	58	72	30	
PFED-54 110/070	157	3,2	101	2	152	21	98	13,5	147	40	95	26	141	58	91	37	
PFED-54 110/085	157	3,2	124	2,4	152	21	121	16	147	40	118	32	141	58	114	46	
PFED-54 129/029	186	3,7	41	0,8	180	25	39	5,5	174	47	37	10	168	69	34	14	
PFED-54 129/037	186	3,7	52	1	180	25	50	7	174	47	48	12,5	168	69	45	18	
PFED-54 129/045	186	3,7	64	1,3	180	25	62	8,5	174	47	60	16	168	69	57	24	
PFED-54 129/056	186	3,7	80	1,6	180	25	78	11	174	47	75	21	168	69	72	30	
PFED-54 129/070	186	3,7	101	2	180	25	98	13,5	174	47	95	26	168	69	91	37	
PFED-54 129/085	186	3,7	124	2,4	180	25	121	16	174	47	118	32	168	69	114	46	
PFED-54 150/029	215	4,2	41	0,8	211	29	39	5,5	204	55	37	10	197	80	34	14	
PFED-54 150/037	215	4,2	52	1	211	29	50	7	204	55	48	12,5	197	80	45	18	
PFED-54 150/045	215	4,2	64	1,3	211	29	62	8,5	204	55	60	16	197	80	57	24	
PFED-54 150/056	215	4,2	80	1,6	211	29	78	11	204	55	75	21	197	80	72	30	
PFED-54 150/070	215	4,2	101	2	211	29	98	13,5	204	55	95	26	197	80	91	37	
PFED-54 150/085	215	4,2	124	2,4	211	29	121	16	204	55	118	32	197	80	114	46	

(1) Max pressure is 160 bar for /PE and /WG versions (2) Max speed is 1800 rpm for /PE versions; 1500 rpm for /WG versions

4 PORT ORIENTATION (pumps viewed from the shaft end)

Pumps can be supplied with the oil ports oriented in different configuration in relation to the drive shaft. Port orientation of the first element is designated as follows (as viewed at the shaft end);

**T** = inlet and outlet ports on the same axis (standard)

**U** = outlet orientated 180° with respect to the inlet

**V** = outlet oriented 90° with respect to the inlet

**W** = outlet oriented 270° with respect to the inlet

Outlet port of second element can be orientated, relative to the inlet port, in 8 positions at 45° (**O, A, B, C, D, E, F, G**)

Ports orientation can be easily changed by rotating the pump body that carries inlet port.

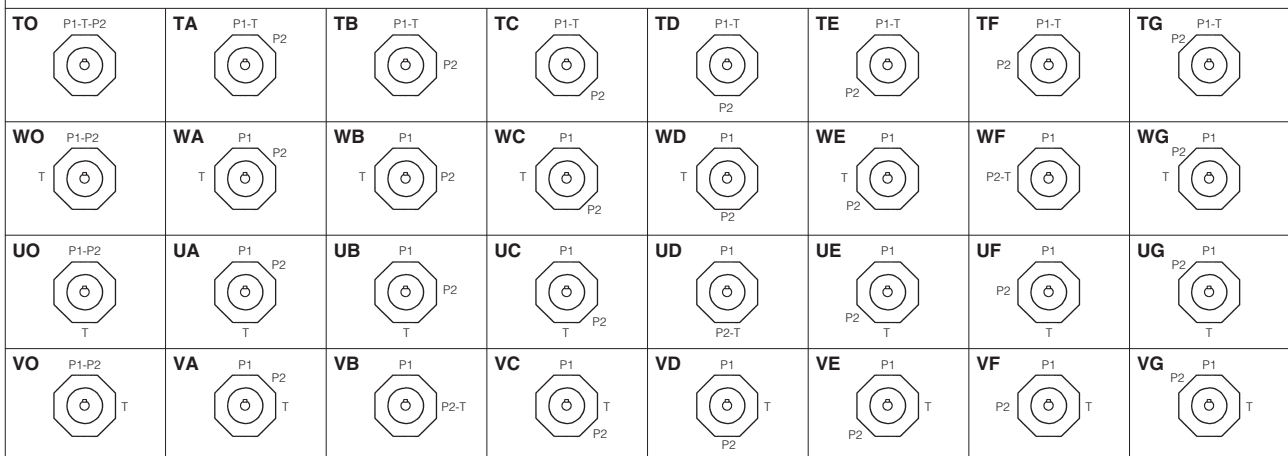

P1 = outlet port of first element; P2 = outlet port of second element; T = inlet port

## 5 DIAGRAMS

### 1 = Torque versus pressure diagram

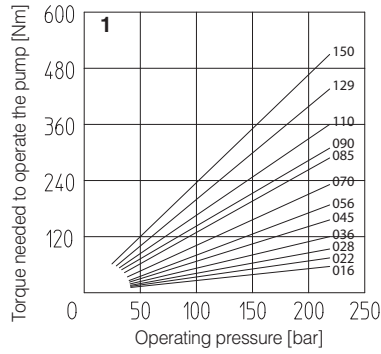

### PFED-43: Second element (cartridge SC-PFED-31\*\*)

2 = Flow versus speed diagram with pressure variation from 7 bar to 210 bar.

3 = Power consumption versus speed diagram at 140 bar. Power consumption is proportional to operating pressure.

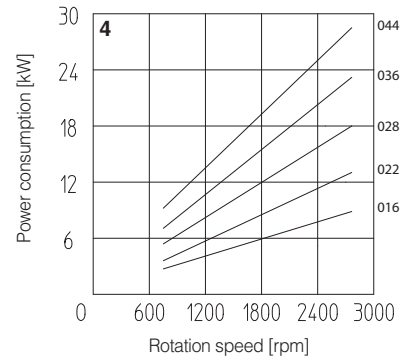
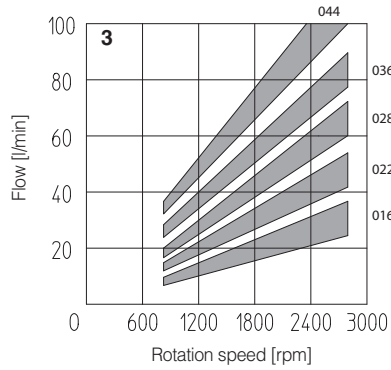

### PFED-43: First element (cartridge SC-PFE-41\*\*)

### PFED-54: Second element (cartridge SC-PFED-41\*\*)

4 = Flow versus speed diagram with pressure variation from 7 bar to 210 bar.

5 = Power consumption versus speed diagram at 140 bar. Power consumption is proportional to operating pressure.

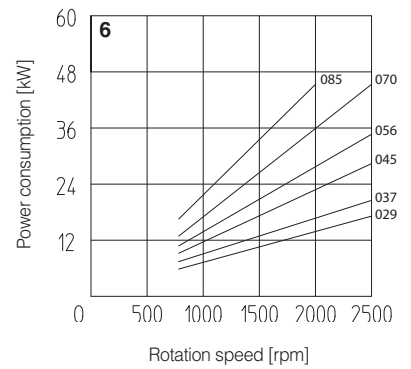
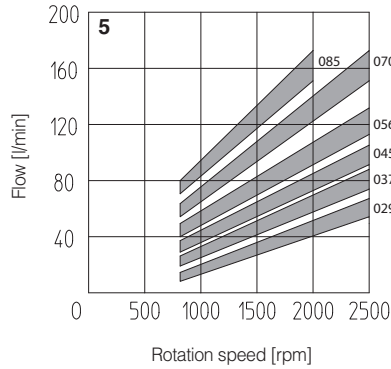

### PFED-54: First element (cartridge SC-PFE-51\*\*)

6 = Flow versus speed diagram with pressure variation from 7 bar to 210 bar.

7 = Power consumption versus speed diagram at 140 bar. Power consumption is proportional to operating pressure.

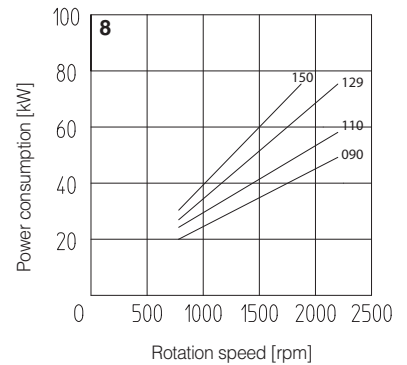
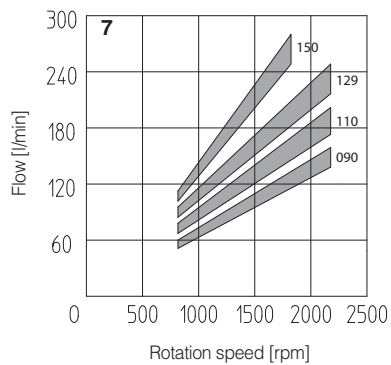

## 6 LIMITS OF SHAFT TORQUE

Pump model	Maximum driving torque [Nm]					
	Shaft type 1	Shaft type 2	Shaft type 3	Shaft type 5	Shaft type 6	Shaft type 7
PFED-43	250	250	400	200	400	400
PFED-54	500	500	850	450	–	–

The values of torque needed to operate each single cartridge are shown on the "torque versus pressure diagram" at section 5. The total torque applied to the shaft of the pump is the sum of the single torque needed for operating each single cartridge and it is necessary to verify that this total torque applied to the drive shaft is not higher than the values indicated in the table.

## 7 DRIVE SHAFT

### CYLINDRICAL SHAFT KEYED

- 1 = supplied as standard if not specified in the model code
- 2 = according to ISO/DIN 3019 standards
- 3 = for high torque applications

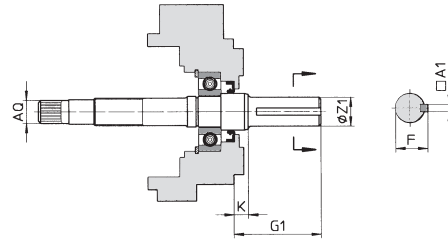

Model	Keyed shaft type 1 (standard)					Keyed shaft type 2					Keyed shaft type 3				
	A1	F	G1	K	ØZ1	A1	F	G1	K	ØZ1	A1	F	G1	K	ØZ1
PFED-43	4,78	24,54	59,00	11,40	22,22	6,38	25,03	71,00	8,00	22,22	6,38	28,30	78,00	11,40	25,38
	4,75	24,41			22,20	6,35	24,77			22,20	6,35	28,10			25,35
PFED-54	7,97	35,33	74,25	14	31,75	7,97	35,33	84,25	8,1	31,75	7,97	38,58	84,25	14	34,90
	7,94	35,07			31,70	7,94	35,07			31,70	7,94	38,46			34,88

### SPLINED SHAFT

- 5 = for PFED-43 according to SAE B 16/32 DP, 13 teeth;  
for PFED-54 according to SAE C 12/24 DP, 14 teeth;
- 6 = (only for PFED-43) according to SAE C 12/24 DP, 14 teeth;
- 7 = only for PFED-43 when used as the last element of a multiple pump: similar to shaft type 6.

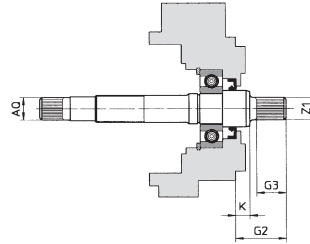

Model	Splined shaft type 5				Splined shaft type 6				Splined shaft type 7			
	G2	G3	K	Z2	G2	G3	K	Z2	G2	G3	K	Z2
PFED-43	41,25	28	8,00	SAE 16/32-13T	55,60	42	8,00	SAE 12/24-14T	41,60	28	8,00	SAE 12/24-14T
PFED-54	55,7	42	8,1	SAE 12/24-14T	—	—	—	—	—	—	—	—

## 8 DIMENSIONS [mm]

### PFED-43

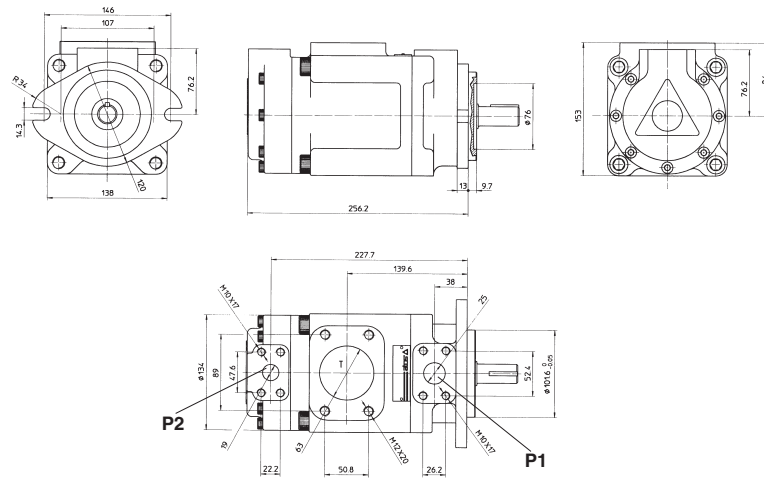

#### SAE FLANGES:

- port P1 = 1";
- port P2 = 3/4";
- port T = 2 1/2"

Weight: 24,5 kg

### PFED-54

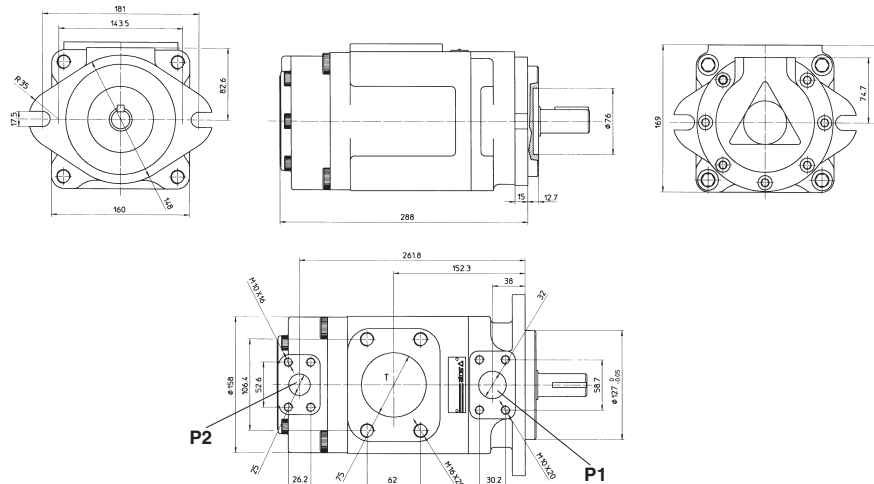

#### SAE FLANGES:

- port P1 = 1 1/4";
- port P2 = 1";
- port T = 3"

Weight: 36 kg