

Cartridge check valves type DB, DR

screw-in mounting - from G1/4" to G1/2"

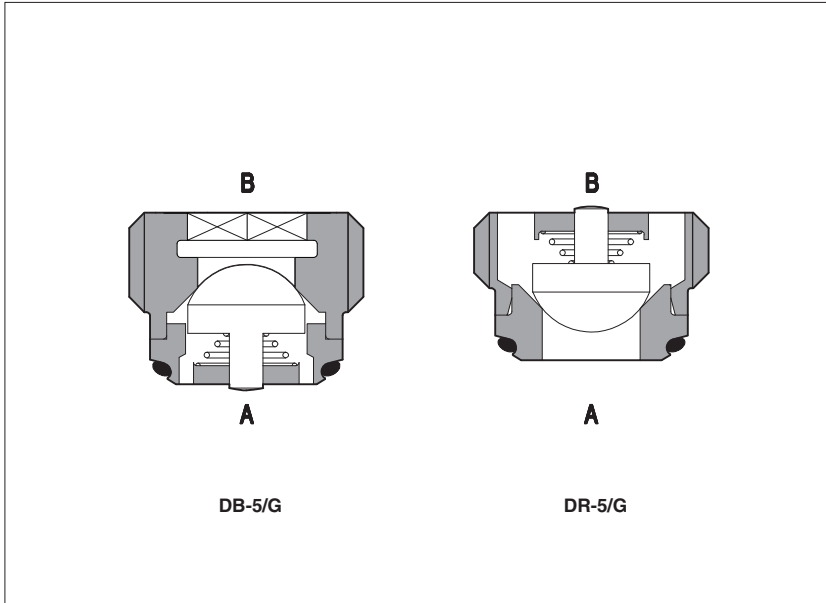

DB, DR are direct operated check valves for screw-in mounting in cavities from G1/4" to G1/2".

They are specifically designed to reduce the manifold dimensions and simplify the installation.

Cartridge designed to operate in hydraulic systems with hydraulic mineral oil or synthetic fluid having similar lubricating characteristics.



Flow up to **95 l/min.**

Max pressure: **500 bar**

1 MODEL CODE

D	B	-	10	/	G	**	/*
Screw-in check valve						Series number	Seals material, see section 3: - = NBR PE = FKM BT = HNBR
B = function A → B R = function B → A							
Size/threated connections: 5 = G 1/4" 10 = G 3/8" 15 = G 1/2"							
				G = Gas threading			

2 HYDRAULIC CHARACTERISTICS

Hydraulic symbol	DB-*/G 	DR-*/G 				
Valve model	DB-5/G	DR-5/G	DB-10/G	DR-10/G	DB-15/G	DR-15/G
Nominal flow (at Δp = 8 bar) [l/min]	25	35	55	65	85	95
Max pressure [bar]	350					
Cracking pressure [bar]	0,3					

3 MAIN CHARACTERISTICS, SEALS AND FLUIDS - for other fluids not included in above table, consult our technical office

Assembly position	Any position		
Ambient temperature	Standard execution = -30°C ÷ +70°C; /PE option = -20°C ÷ +70°C; /BT option = -40°C ÷ +70°C		
Seals, recommended fluid temperature	NBR seals (standard) = -20°C ÷ +60°C, with HFC hydraulic fluids = -20°C ÷ +50°C FKM seals (/PE option) = -20°C ÷ +80°C HNBR seals (/BT option) = -40°C ÷ +60°C, with HFC hydraulic fluids = -40°C ÷ +50°C		
Recommended viscosity	15 ÷ 100 mm ² /s - max allowed range 2,8 ÷ 500 mm ² /s		
Fluid contamination class	ISO 4406 class 21/19/16 NAS 1638 class 10, in line filters of 25 μm (β ₁₀ ≥ 75 recommended)		
Flow direction	As shown in the symbol at section 2		
Rated flow	See diagrams Q/Δp at section 4		
Hydraulic fluid	Suitable seals type	Classification	Ref. Standard
Mineral oils	NBR, FKM, HNBR	HL, HLP, HLPD, HVLP, HVLDP	DIN 51524
Flame resistant without water	FKM	HFDU, HFDR	ISO 12922
Flame resistant with water	NBR, HNBR	HFC	

4 FLOW VERSUS PRESSURE DROP DIAGRAMS based on mineral oil ISO VG 46 at 50°C

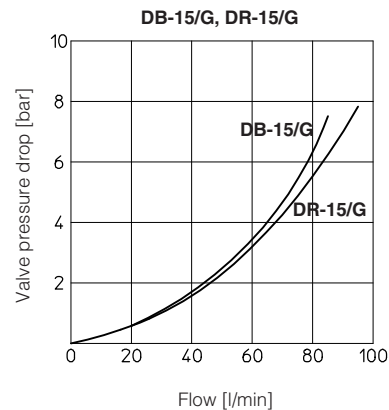
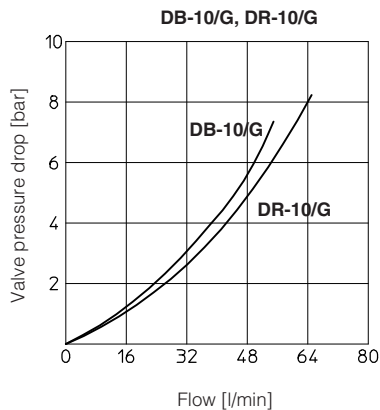
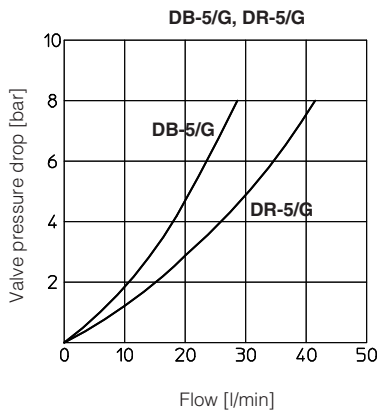

5 RECESS DIMENSIONS [mm]

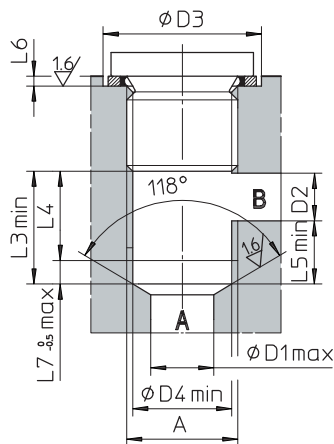
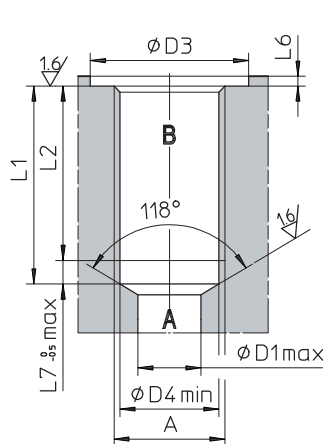

	A	D1	D2	D3	D4	L1	L2	L3	L4	L5	L6	L7
DB-5/G	G 1/4"	8	6	22	11,6	22	19	14	11	8	1,5	3
DR-5/G												
DB-10/G	G 3/8"	9	8	26	15	24	21	17	14	9	1,5	3
DR-10/G												
DB-15/G	G 1/2"	12	12	30	18,75	28	24,5	22	18,5	10	1,5	3,5
DR-15/G												

6 VALVE DIMENSIONS [mm]

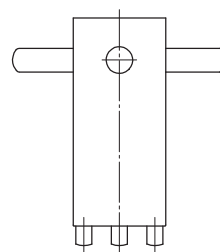
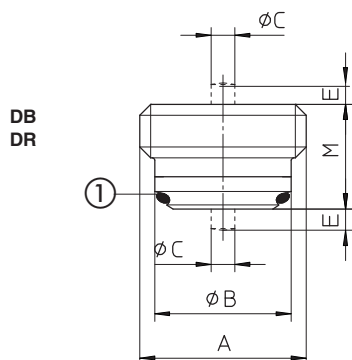

***-DRG-205000**

Note: this special key is required for assembling the valve in the cavity

	A	B	C	E	M	①	Mass (Kg)
DB-5/G	G 1/4"	11,5	2,1	1,5	10,3	OR-9x1/70	0,060
DR-5/G			2,4		9		
DB-10/G	G 3/8"	15	2,8	2	11,3	OR-11x1,5/70	0,012
DR-10/G			3,3		2,5		
DB-15/G	G 1/2"	18,5	3,2	2,5	12,9	OR-14x1,5/70	0,020
DR-15/G			4		2,5		

	A	KEY	Tightening torque (Nm)
DB-5/G	G 1/4"	CH 7 ◯	15
DR-5/G		5-DRG-205000	
DB-10/G	G 3/8"	CH 6 ◯	20
DR-10/G		10-DRG-205000	
DB-15/G	G 1/2"	CH 8 ◯	40
DR-15/G		15-DRG-205000	