

Analog electronic AE drivers

integral-to-valve format, for proportional valves without transducer

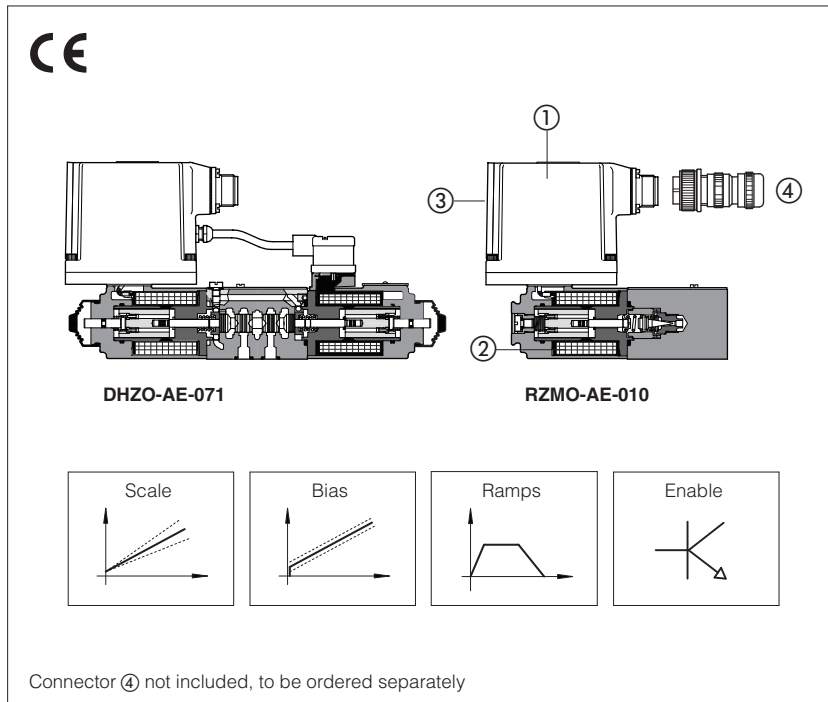

AE

Analog integral drivers ① supply and control the current to the solenoid of Atos proportional valves without transducer, according to the electronic reference input signal.

The solenoid ② proportionally transforms the current into a force, acting on the valve spool or poppet, against a reacting spring, thus providing the valve's hydraulic regulation.

AE can drive one single or one double solenoid proportional valve.

Features:

- Integral-to-valve analog electronics, factory preset for best performances
- Potentiometer adjustment ③ of bias, scale and ramps
- Standard 7 pin main connector ④ for power supply, analog input reference and monitor signals
- Switch selector for dither frequency adjustment
- IP67 protection degree
- CE mark according to EMC directive

1 VALVES RANGE

Valves model	Pressure				Directional			Cartridge	Flow	
	RZMO	RZGO	AGMZO	AGRCZO	DHZO	DKZOR	DPZO	LI*ZO	QVHZO	QVKZOR
Data sheet	F007 F065	F015 F070	F035	F050	F160		F170	F300	F410	
Driver model	AE									

2 MAIN CHARACTERISTICS

Power supply	Nominal: +24 Vdc Rectified and filtered: $V_{RMS} = 21 \div 32 V_{MAX}$ (ripple max 10 % V_{PP})
Max power consumption	50 W
Reference input signal	Input impedance: voltage $R_i > 50 \text{ k}\Omega$ (range $\pm 10 \text{ Vdc}$) current $R_i = 316 \Omega$ (range $4 \div 20 \text{ mA}$)
Monitor output	Output range : $\pm 10 \text{ Vdc}$ @ max 5 mA
Enable input	Input impedance: $R_i > 10 \text{ k}\Omega$; range : $0 \div 5 \text{ Vdc}$ (OFF state), $9 \div 24 \text{ Vdc}$ (ON state), $5 \div 9 \text{ Vdc}$ (not accepted)
Alarms	Cable break with current reference signal
Format	Sealed box on the valve; IP67 protection degree
Operating temperature	$-20 \div +60 \text{ }^\circ\text{C}$ (storage $-20 \div +70 \text{ }^\circ\text{C}$)
Mass	Approx. 385 g
Additional characteristics	Short circuit protection of solenoid's current supply; solenoid current control by P.I.D. with rapid solenoid switching
Electromagnetic compatibility (EMC)	According to Directive EN2004/108/CE (Immunity: EN 50082-2; Emission: EN 50081-2)
Calibrations	Remove the rear cover to access bias, scale, ramps and dither regulations
Recommended wiring cable (see [7])	LiYCY shielded cables

Note: a minimum time of 60 ms to 160 ms have be considered between the driver energizing with the 24 Vdc power supply and when the valve is ready to operate. During this time the current to the valve coils is switched to zero

3 CONNECTIONS AND SETTINGS

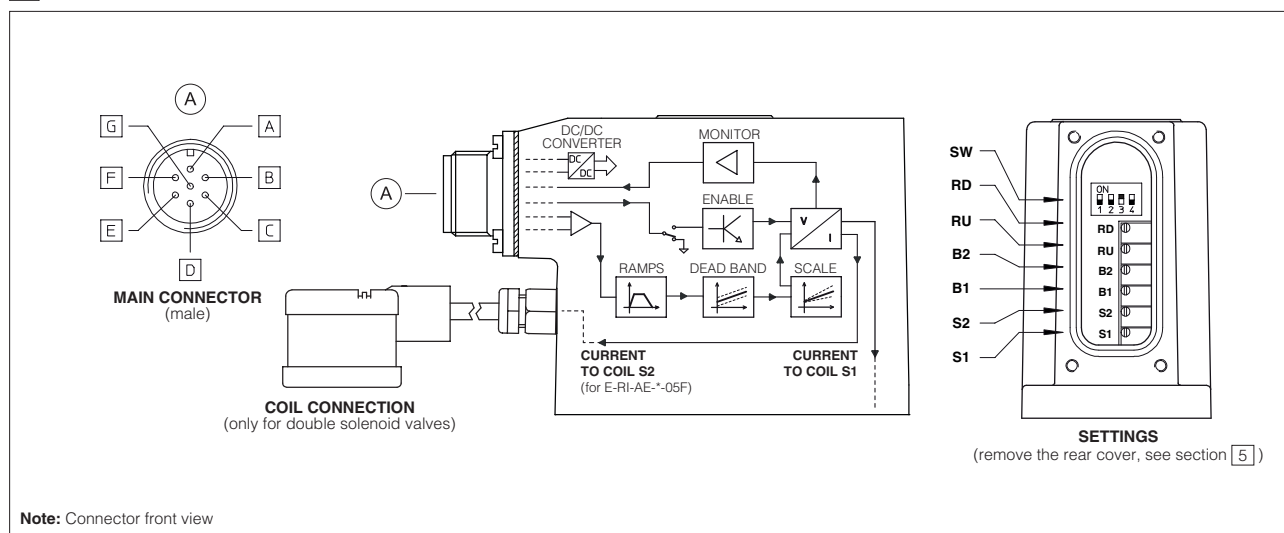

3.1 Main connector- 7 pin (A)

PIN	SIGNAL	TECHNICAL SPECIFICATIONS	NOTES
A	V+	Power supply 24 Vdc for solenoid power stage and driver logic	Input - power supply
B	V0	Power supply 0 Vdc for solenoid power stage and driver logic	Gnd - power supply
C	AGND	Ground - signal zero for MONITOR signal	Gnd - analog signal
	ENABLE	Enable (24 Vdc) or disable (0 Vdc) the driver (for /Q option) With /Q option:ENABLE signal replaces AGND on pin C; MONITOR signal is referred to pin B	Input - on/off signal
D	INPUT+	Reference analog differential input: ± 10 Vdc maximum range (4 \div 20 mA for /I option) For single solenoid valves the reference input is 0 \div 10 Vdc (4 \div 20 mA for /I option)	Input - analog signal
E	INPUT -	For double solenoid valves the reference input is ± 10 Vdc (4 \div 20 mA for /I option)	
F	MONITOR	Monitor analog output: ± 5 Vdc maximum range (1V monitor = 1A coil current) For single solenoid valves: 0 \div 5 Vdc referred to pin C (for /I option) 0 \div 5 Vdc referred to pin B (for /Q option) For double solenoid valves: ± 5 Vdc referred to pin C (for /I option) ± 5 Vdc referred to pin B (for /Q option)	Output - analog signal
G	EARTH	Internally connected to the driver housing	

4 OPTIONS

Standard driver execution provides on the 7 pin main connector:

Power supply - 24 Vdc must be appropriately stabilized or rectified and filtered; a 2,5 A safety fuse is required in series to the driver power supply.
Apply at least a 10000 μ F/40 V capacitance to single phase rectifiers or a 4700 μ F/40 V capacitance to three phase rectifiers

Reference input signal - analogue differential input with ± 10 Vdc nominal range (pin D,E), proportional to desired coil current

Monitor output signal - analog output signal proportional to the actual valve's coil current (1V monitor = 1A coil current)

Atos drivers are CE marked according to the applicable directives (e.g. Immunity/Emission EMC Directive).

Installation, wirings and start-up procedures must be performed according to the general prescriptions shown in tech table **F003**.

The electrical signals of the valve (e.g. monitor signals) must not be directly used to activate safety functions, like to switch-ON/OFF the machine's safety components, as prescribed by the European standards (Safety requirements of fluid technology systems and components-hydraulics, EN-982)

Following options are available to adapt standard execution to special application requirements:

4.1 Option /I

It provides the 4 \div 20 mA current reference signal instead of the standard ± 10 Vdc; Monitor output signal is still the standard ± 10 Vdc.

It is normally used in case of long distance between the machine control unit and the valve or whenever the reference signal can be affected by electrical noise; the valve functioning is disabled in case of reference signal cable breakage.

4.2 Option /Q

It provides the possibility to enable or disable the valve functioning without cutting the power supply (the valve functioning is disabled but the driver current output stage is still active). To enable the driver supply a 24 Vdc on the enable input signal.

4.3 Possible combined options: /IQ

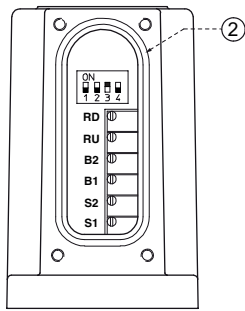

REAR COVER

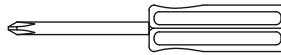
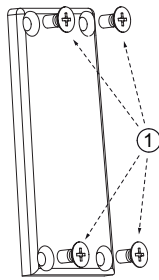

Note: remove the 4 screws ① of driver's rear cover to access user settings

Warning: before to close the rear cover check correct positioning of the seal ②

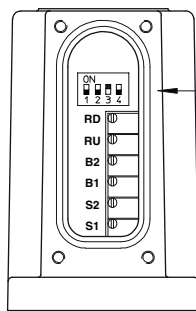

DITHER

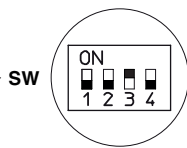

Factory preset

Selector SW				Dither frequency [Hz]
SW1	SW2	SW3	SW4	
OFF	OFF	OFF	OFF	100
ON	OFF	OFF	OFF	130
OFF	ON	OFF	OFF	160
OFF	OFF	ON	OFF	200 (*)
ON	OFF	ON	OFF	230
OFF	ON	ON	OFF	270
ON	ON	ON	OFF	300
ON	ON	OFF	ON	380
ON	OFF	ON	ON	430
OFF	ON	ON	ON	470
ON	ON	ON	ON	500

(*) Dither frequency is factory preset at 200 Hz and its regulation may be adjusted after contact Atos technical office.

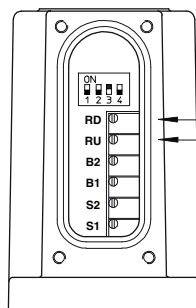

RISING AND FALLING RAMPS

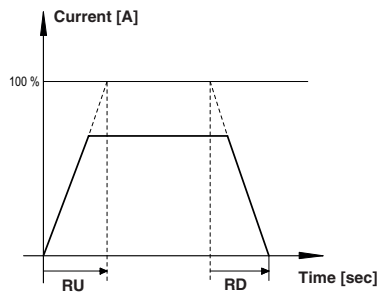

RU ramp for increasing reference signal
RD ramp for decreasing reference signal

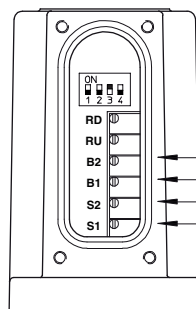

BIAS AND SCALE

Single solenoid directional control valve, two positions with positive overlapping

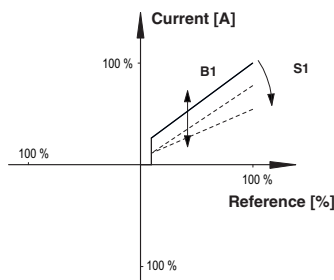

B1 bias adjust
S1 scale adjust

Threshold = 2 %
(±200 mV or 0,32 mA for /I option)

Double solenoid directional control valve, three position with positive overlapping

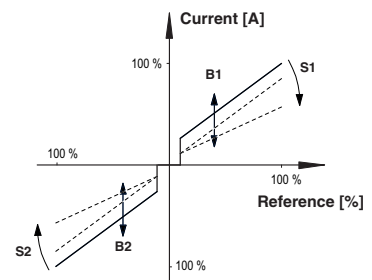

B1 positive bias adjust
S1 positive scale adjust
B2 negative bias adjust
S2 negative scale adjust

Threshold = 2 %
(±200 mV or ±0,16 mA for /I option)

6 OVERALL DIMENSIONS [mm]

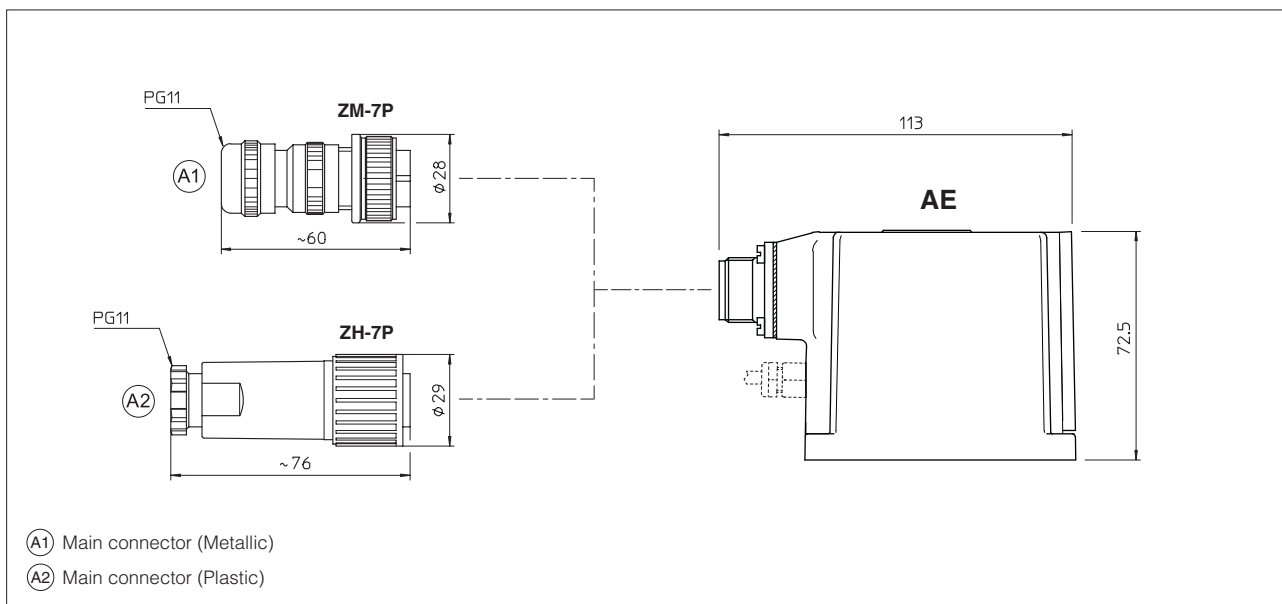

7 CONNECTORS CHARACTERISTICS - to be ordered separately

CONNECTOR TYPE	POWER SUPPLY	POWER SUPPLY
CODE	(A1) ZM-7P	(A2) ZH-7P
Type	7pin female straight circular	7pin female straight circular
Standard	According to MIL-C-5015	According to MIL-C-5015
Material	Metallic	Plastic reinforced with fiber glass
Cable gland	PG11	PG11
Cable	LiYCY 7 x 0,75 mm ² max 20 m LiYCY 7 x 1 mm ² max 40 m	LiYCY 7 x 0,75 mm ² max 20 m LiYCY 7 x 1 mm ² max 40 m
Connection type	to solder	to solder
Protection (EN 60529)	IP 67	IP 67

8 MODEL CODE FOR SPARE PARTS

integral drivers are available as spare parts only for Atos authorized service centers.

E-RI	-	AE	-	01F	/	*	/	*
Integral electronic driver								Set code (1)
AE = for proportional valves without transducer				Series number				
01F = for single solenoid proportional valve 05F = for double solenoid proportional valve				Options , see section [4]: - = standard voltage reference input (± 10 VDC) I = current reference input ($4 \div 20$ mA) Q = enable signal				

(1) set code identifies the correspondance between the integral driver and the relevant valve; it is assigned by Atos when the driver is ordered as spare part