

# Digital electronic TERS/AERS drivers

integral-to-valve format, for proportional valves with one integral or remote pressure transducer

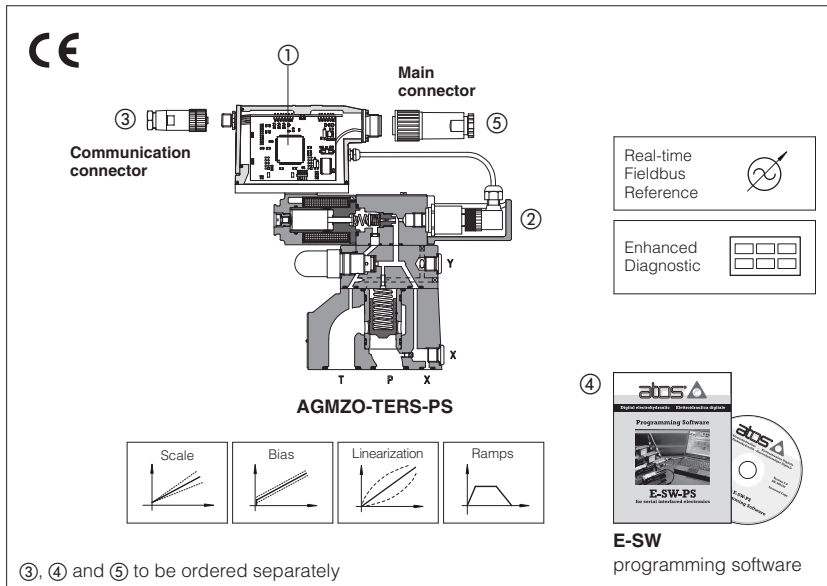

## TERS, AERS

These integral digital drivers ① supply and control, in closed loop, the regulated pressure of direct and pilot operated proportional valves according to the electronic reference input signal.

TERS execution operates direct and pilot operated relief/reducing control valves with one integral pressure transducer ②. AERS execution operates direct and pilot operated relief/reducing control valves with one remote pressure transducer.

Digital communication interface ③ allows to program the drivers with the Atos PC software ④.

Drivers executions with fieldbus communication interface (CANopen or PROFIBUS DP) are available to program and command the valves directly by the machine control unit.

### Electrical Features:

- Functional parameters are factory preset for best performances
- Standard 7 pin main connector ⑤ for power supply, analog input reference and monitor signals
- /Z option 12 pin main connector for additional double power supply, enable and fault signals
- /I option for current reference and monitor signals
- /C option for current interface with remote pressure transducer
- 5 pin connector ③ for communication interface, at choice: serial PS or fieldbus BC and BP
- IP67 protection degree
- CE mark according to EMC directive

### Software Features:

- Setting of valve's functional parameters: bias, scale, ramps, dither
- Linearization function for the hydraulic regulation
- Setting of valve's dynamic response (PID) to optimize the application performances
- Range selection for the electronic reference analog inputs: voltage or current (/I option)
- Complete diagnostics of driver status, solenoid and fault conditions
- Intuitive graphic interface

## 1 MODEL CODE FOR SPARE PARTS

Integral drivers are available as spare parts only for Atos authorized service centers.

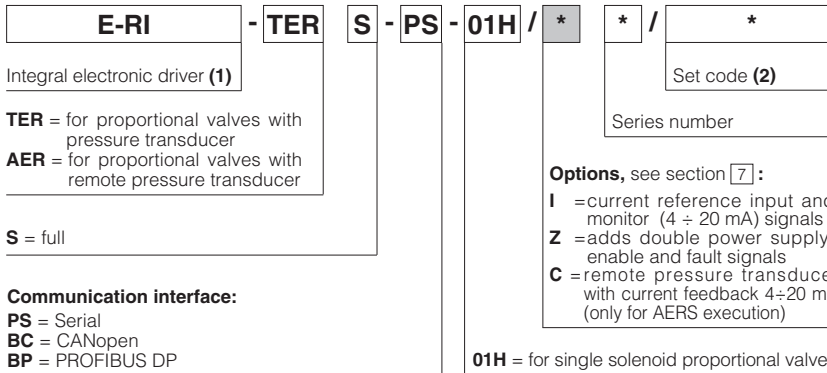

(1) for Ex-proof execution, please contact Atos technical department

(2) set code identifies the correspondence between the integral driver and the relevant valve; it is assigned by Atos when the driver is ordered as spare part

## 2 BLOCK DIAGRAM - standard

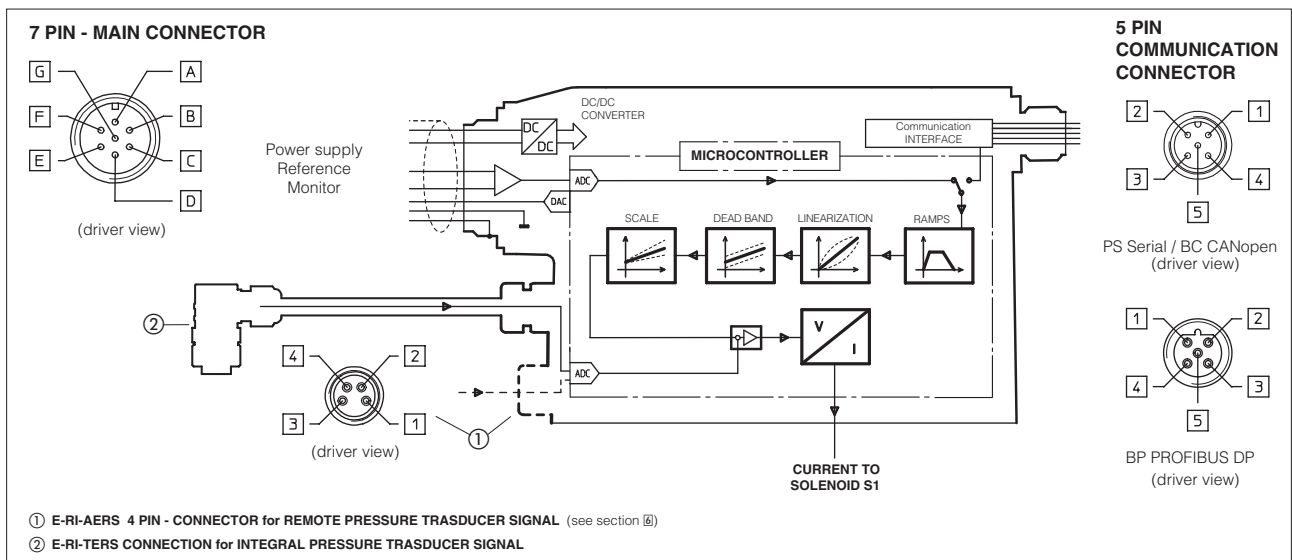

### 3 BLOCK DIAGRAM - /Z option

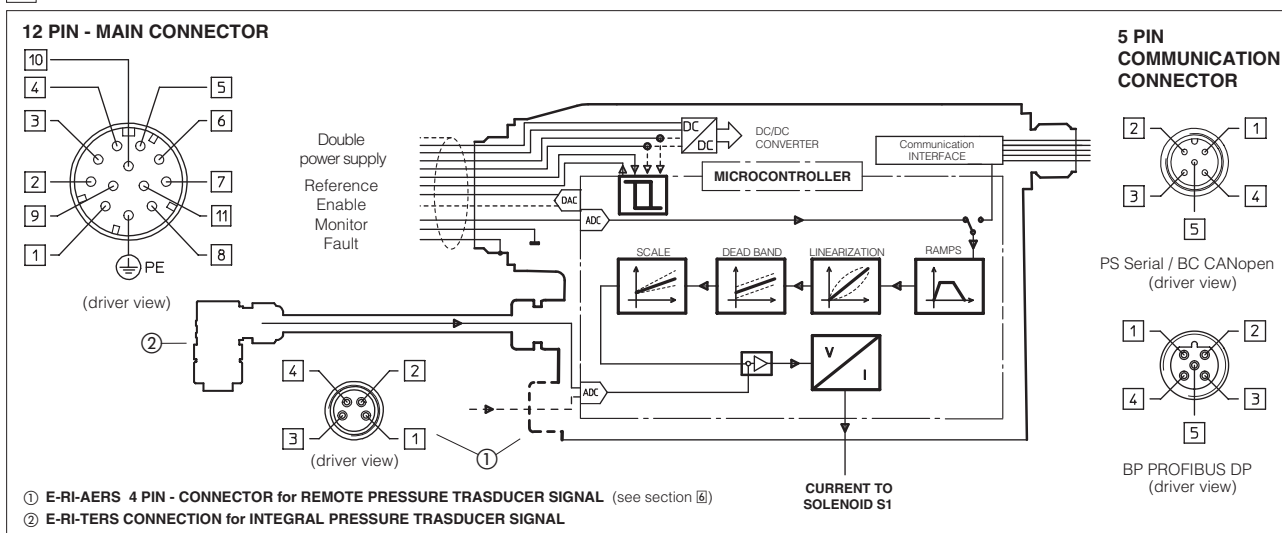

### 4 ELECTRONIC CONNECTIONS - 7 or 12 PIN MAIN CONNECTOR

Standard 7pin	/Z option 12pin	SIGNAL	TECHNICAL SPECIFICATIONS	NOTES
A	1	V+	Power supply 24 Vdc for solenoid power stage (see 7.1)	Input - power supply
B	2	V0	Power supply 0 Vdc for solenoid power stage (see 7.1)	Gnd - power supply
-	3	ENABLE	Enable (24 Vdc) or disable (0 Vdc) the driver (see 7.5)	Input - on/off signal
D	4	INPUT+	Reference analog input: $\pm 10$ Vdc maximum range ( $4 \div 20$ mA for /I option) - see 7.2 differential INPUT+ and INPUT- (for 7 pin standard execution) common mode INPUT+ referred to AGND (for 12 pin /Z option)	Input - analog signal
E	-	INPUT -		
C	5	AGND	Ground : signal zero for MONITOR signal ( pin F of 7 pin standard or pin 6 of /Z option) signal zero for INPUT+ signal ( pin 4 of /Z option)	Gnd - analog signal
F	6	MONITOR	Monitor analog output: $\pm 10$ Vdc maximum range ( $4 \div 20$ mA for /I option) - see 7.3	Output - analog signal
-	7	NC	do not connect	
-	8	NC	do not connect	
-	9	VL+	Power supply 24 Vdc for driver logic (see 7.4)	Input - power supply
-	10	VL0	Power supply 0 Vdc for driver logic (see 7.4)	Gnd - power supply
-	11	FAULT	Driver status : Fault (0Vdc) or normal working (24 Vdc) (see 7.6)	Output - on/off signal
G	PE	EARTH	Internally connected to driver housing	

**Note:** A minimum time of 270 to 590 ms have to be considered between the driver energizing with the 24 Vdc power supply and when the valve is ready to operate. During this time the current to the valve coils is switched to zero.

### 5 ELECTRONIC CONNECTIONS - 5 PIN COMMUNICATION M12 CONNECTOR

PIN	PS Serial		BC CANopen		BP PROFIBUS DP	
	SIGNAL	TECHNICAL SPECIFICATION	SIGNAL	TECHNICAL SPECIFICATION	SIGNAL	TECHNICAL SPECIFICATION
1	NC	do not connect	CAN_SHLD	Shield	+5V	for termination
2	NC	do not connect	NC	do not connect	LINE-A	Bus line (high)
3	RS_GND	Signal zero data line	CAN_GND	Signal zero data line	DGND	data line and termination Signal zero
4	RS_RX	Valves receiving data line	CAN_H	Bus line (high)	LINE-B	Bus line (low)
5	RS_TX	Valves transmitting data line	CAN_L	Bus line (low)	SHIELD	

### 6 ELECTRONIC CONNECTIONS - 4 PIN REMOTE PRESSURE TRASDUCER M8 CONNECTOR - only for AERS

PIN	standard version	/C option (Ri = 316 Ω)
1	TR remote trasducer pressure signal (0 ÷ 10 Vdc)	TR remote trasducer pressure signal (4 ÷ 20 mA)
2	NC reserved (do not connect)	NC reserved (do not connect)
3	VT remote trasducer power supply +24 Vdc	VT remote trasducer power supply +24 Vdc
4	AGND signal zero for power supply and signal	NC reserved (do not connect)

**Note:** see tech table G465 for the pressure transducer characteristics and connections

### 7 SIGNALS SPECIFICATIONS

Atos proportional valves are CE marked according to the applicable directives (e.g. Immunity/Emission EMC Directive). Installation, wirings and start-up procedures must be performed according to the general prescriptions shown in tech table F003 and in the user manuals included in the E-SW programming software.

The electrical signals of the valve (e.g. monitor signals) must not be directly used to activate safety functions, like to switch-ON/OFF the machine's safety components, as prescribed by the European standards (Safety requirements of fluid technology systems and components-hydraulics, EN-982).

#### 7.1 Power supply (V+ and V0)

The power supply must be appropriately stabilized or rectified and filtered: apply at least a 10000  $\mu$ F/40 V capacitance to single phase rectifiers or a 4700  $\mu$ F/40 V capacitance to three phase rectifiers.

A safety fuse is required in series to each driver power supply: 2,5 A fuse.

Note: pin 2 and 10 (zero Volt) are connected together inside the electronics.

#### 7.2 Enable input signal (ENABLE) - only for /Z option

To enable the driver, supply a 24 Vdc on pin 3 referred to pin 2: Enable input signal allows to enable/disable the current supply to the solenoid, without removing the electrical power supply to the driver; it is used to active the communication and the other driver functions when the valve must be disabled for safety reasons. This condition does not comply with European Norms EN13849-1 (ex EN954-1)

### 7.3 Reference input signal (INPUT+ and INPUT-)

The driver controls in closed loop the valve pressure proportionally to the external reference signal input. The driver is designed to receive one analog reference input (pin D,E differential mode input). The input range and polarity are software selectable within the  $\pm 10$  Vdc maximum range; default settings is  $0 \div 10$  Vdc. Drivers with fieldbus interface (-BC or -BP) can be software set to receive reference value directly by the machine control unit (fieldbus master); in this case the analog reference input signal can be used for start-up and maintenance operations.

#### Option /I

The maximum range of reference input signal is software selectable among  $4 \div 20$  mA (default with cable break detection),  $\pm 10$ mA,  $\pm 20$ mA or  $0 \div 20$ mA

#### Option /Z

The reference input is available in common mode (pin 4 referred to pin 5) instead of the standard differential mode

### 7.4 Monitor output signal (MONITOR)

The driver generates an analog output signal proportional to the actual pressure of the valve (pin F/6 referred to pin C/5); the monitor output signal can be software set to show other signals available in the driver (e.g. analog reference, fieldbus reference).

The output range and polarity are software selectable within  $\pm 10$  Vdc maximum range; default settings is  $0 \div 10$  Vdc.

#### Option /I

The maximum range of monitor output signal is  $4 \div 20$  mA

### 7.5 Power supply for driver's logic and communication (VL+ and VL0) - only for /Z option

Option /Z provides separate power supply for the solenoid (pin 1,2) and for the digital electronic circuits (pin 9,10).

Cutting solenoid power supply allows to interrupt the valve functioning but keeping energized the digital electronics thus avoiding fault conditions of the machine fieldbus controller. This condition allows to realize safety systems in compliance with European Norms EN13849-1 (ex EN954-1).

A safety fuse is required in series to each driver power supply: 500 mA fast fuse.

Note: pin 2 and 10 (zero Volt) are connected together inside the electronics.

### 7.6 Fault output signal (FAULT) - only for /Z option

Fault output signal indicates fault conditions of the driver (solenoid short circuits/not connected, reference signal cable broken for  $4 \div 20$ mA input, pressure transducer cable broken, etc.). Fault presence corresponds to 0 Vdc, normal working corresponds to 24 Vdc (pin 11 referred to pin2).

Fault status is not affected by the Enable input signal

### 7.7 Remote pressure transducer signal (TR) - only for AERS (see section 6)

Remote pressure transducer with maximum  $0 \div 10$  Vdc output signal can be directly connected to the driver; refer to the valve's technical table to select the transducer's maximum pressure.

#### Option /C

The maximum range of remote pressure transducer signal is software selectable among  $4 \div 20$  mA (default with cable break detection) or  $0 \div 20$  mA

### 7.8 Possible combined options: /CI, /CIZ, /CZ (only for AERS) and /IZ.

## 8 PROGRAMMING TOOLS - see tech table GS500

Valve's functional parameters and configurations, can be easily set and optimized using Atos E-SW programming software connected to the digital driver. E-SW software is available in different versions according to the driver's communication interface: PS (Serial) E-SW-PS, BC (CANopen) E-SW-BC and BP (PROFIBUS DP). Proportional valves with fieldbus communication interface can be directly managed by the machine control unit; it is required to implement in the machine control the standard communication as described in the user manuals supplied with the relevant programming software.

### Basic programming software, free download :

**E-SW-PS** web download = software can be downloaded upon web registration at [www.download.atos.com](http://www.download.atos.com) ; service and DVD not included  
Upon web registration user receive via email the Activation Code (software free license) and login data to access Atos Download Area. The software remains active for 10 days from the installation date and then it stops until the user inputs the Activation Code.

### Full programming software, to be ordered separately :

**E-SW-\*** DVD first supply = software has to be activated via web registration at [www.download.atos.com](http://www.download.atos.com) ; 1 year service included  
Upon web registration user receive via email the Activation Code (software license) and login data to access personal Atos Download Area. The software remains active for 10 days from the installation date and then it stops until the user inputs the Activation Code.

**E-SW-\*-N** DVD next supplies = only for supplies after the first; service not included, web registration not allowed  
Software has to be activated with Activation Code received upon first supply web registration

**Atos Download Area:** direct access to latest releases of E-SW software, manuals, USB drivers and fieldbus configuration files at [www.download.atos.com](http://www.download.atos.com)

**USB Adapters, Cables and Terminators, can be ordered separately**

## 9 MAIN SOFTWARE PARAMETER SETTINGS

The following is a brief description of the main settings and features of digital drivers. For a detailed descriptions of available settings, wirings and installation procedures, please refer to the user manual included in the E-SW-\* DVD programming software:

### E-MAN-RI-TERS - user manual for TERS and AERS

#### 9.1 Scale

Scale function allows to set the maximum valve pressure at maximum reference signal value. This regulation allows to reduce the maximum valve regulation in front of maximum reference signal.

#### 9.2 Bias

Pressure proportional valves are limited in the minimum regulated pressure: the minimum pressure depends on the valve size, the regulated flow (only for relief valves) and the T port pressure. Desired pressure requested through the reference signal (analog or fieldbus external input), must be greater than the minimum pressure to obtain the valve's best repeatability and response time. The Bias function can be set to limit internally the minimum pressure reference independently from the external reference value thus optimizing valve's performances. Refer to the programming manuals for a detailed description of other software selectable Bias functions.

#### 9.4 Ramps

The ramp generator allows to convert sudden change of electronic reference signal into smooth time-dependent increasing/decreasing of the valve opening.

Different ramp mode can be set:

- single ramp for any reference variation
- two ramps for increasing and for decreasing reference variations

Ramp generator is useful for application where smooth hydraulic actuation is necessary to avoid machine vibration and shocks.

If the proportional valve is driven by a closed loop controller, the ramps can lead to unstable behaviour, for these applications ramp function can be software disabled (default setting).

#### 9.5 Linearization

Linearization function allows to set the relation between the reference input signal and the controlled valve's pressure. Linearization is useful for applications where it is required to linearize the valve's regulation in a defined working condition.

#### 9.6 Dither

The dither is an high frequency modulation added to the valve's reference signal to reduce the hysteresis of the valve's regulation; in fact a small vibration in the valve's hydraulic regulation considerably reduces the mechanical friction effects (e.g. due to cylinder seals). Dither frequency and amplitude are software selectable; the amplitude is automatically reduced at high reference values to avoid possible instability.

Lower frequency and higher amplitude reduce hysteresis but also reduce the regulation stability. In some application this can lead to vibration and noise: right setting usually depends on system setup. Dither default setting is disabled.

#### 9.7 Multiple pressure PID - only for BC or BP execution

Four sets for pressure PID parameters are stored into the driver: fieldbus communication allows real-time switching of active pressure PID parameters during machine cycle optimizing the system dynamic response in different hydraulic working conditions (volume, flow, etc.).

#### 9.8 Transducer Scale - only for AERS

Transducer Scale function allows to adapt the driver to remote transducers with different output signal range and nominal pressure.

### 9.1, 9.2 - Scale and Bias

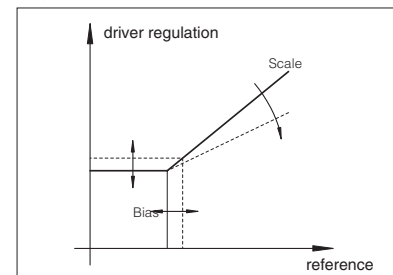

### 9.4 - Ramps

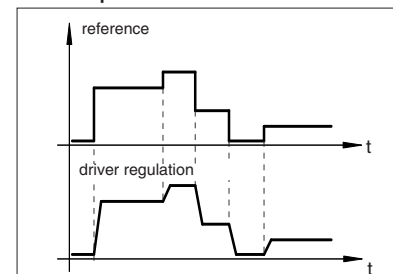

### 9.5 - Linearization

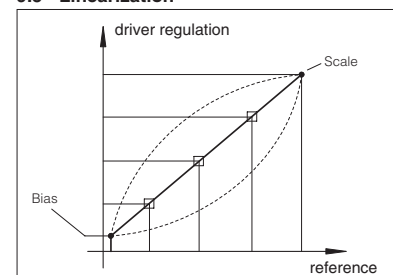

## 10 MAIN CHARACTERISTICS

Power supply (1) - (see 7.1, 7.4)	Nominal : +24 Vdc Rectified and filtered : $V_{RMS} = 20 \div 32 V_{MAX}$ (ripple max 10 % $V_{PP}$ )		
Max power consumption	50 W		
Reference input signal (see 7.2)	Voltage: range $\pm 10 V_{dc}$ Current: range $4 \div 20 mA$	Input impedance: $R_i > 50 k\Omega$ Input impedance: $R_i = 316 \Omega$	
Monitor output (see 7.3)	Output range : voltage $\pm 10 V_{dc}$ @ max 5 mA current $4 \div 20 mA$ @ max 500 $\Omega$ load resistance		
Enable input (see 7.5)	Range : $0 \div 5 V_{dc}$ (OFF state), $9 \div 24 V_{dc}$ (ON state), $5 \div 9 V_{dc}$ (not accepted) Input impedance: $R_i > 10 k\Omega$		
Fault output (2) - (see 7.6)	Output range : $0 \div 24 V_{dc}$ ( ON state > [power supply - 2 V] ; OFF state < 1 V ) @ max 50 mA		
Alarms	Solenoid not connected/short circuit, cable break with current reference signal, overtemperature, under temperature, valve pressure trasducer cable break		
Format	Sealed box on the valve; IP67 protection degree		
Operating temperature	$-20 \div +50 ^\circ C$ (storage $-20 \div +70 ^\circ C$ )		
Mass	Approx. 480 g		
Additional characteristics	Short circuit protection of solenoid's current supply; pressure control by P.I.D. with rapid solenoid switching		
Electromagnetic compatibility (EMC)	According to Directive 2004/108/CE (Immunity: EN 50082-2; Emission: EN 50081-2)		
Communication interface	Serial Atos ASCII coding	CANopen EN50325-4 + DS408	PROFIBUS EN50170-2/IEC61158
Communication physical layer	not insulated serial RS232	optical insulated CAN ISO11898	optical insulated RS485
Recommended wiring cable	LIYCY shielded cables: $0,5 mm^2$ for length up to 40 m [ $1,5 mm^2$ for power supply and solenoid]		

**Notes:** (1) nominal data for solenoid power stage and driver logic (2) external negative voltage not allowed (e.g. due to inductive loads)

## 11 MAIN CONNECTOR CHARACTERISTICS - to be ordered separately

CODE	ZH-7P	ZM-7P	ZH-12P
Type	Female straight circular socket plug 7pin	Female straight circular socket plug 7pin	Female straight circular socket plug 12pin
Standard	According to MIL-C-5015	According to MIL-C-5015	DIN 43651
Material	Plastic reinforced with fiber glass	Metallic	Plastic reinforced with fiber glass
Cable gland	PG11	PG11	PG16
Cable	LIYCY 7x 0,75 mm <sup>2</sup> max 20 m 7 x 1 mm <sup>2</sup> max 40 m	LIYCY 7x 0,75 mm <sup>2</sup> max 20 m 7 x 1 mm <sup>2</sup> max 40 m	LIYCY 10 x 0,14 mm <sup>2</sup> (signal) LiYY 3 x 1 mm <sup>2</sup> (power supply)
Connection type	to solder	to solder	to crimp
Protection (EN 60529)	IP 67	IP 67	IP 67

## 12 COMMUNICATION CONNECTOR CHARACTERISTICS - to be ordered separately

CODE	PS Serial Connector	BC CANopen Connector (1)	BP PROFIBUS DP Connector (1)
	ZH-5P	ZH-5P	ZH-5P/BP
Type	Female straight circular socket plug 5 pin	Female straight circular socket plug 5 pin	Male straight circular socket plug 5 pin
Standard	M12 – IEC 60947-5-2	M12 – IEC 60947-5-2	M12 – IEC 60947-5-2
Material	Plastic	Plastic	Plastic
Cable gland	PG9	PG9	PG9
Cable	LIYCY 5x0,25 mm <sup>2</sup> shielded	CANBus Standard (DR303-1)	PROFIBUS DP Standard
Connection type	screw terminal	screw terminal	screw terminal
Protection (EN 60529)	IP 67	IP 67	IP 67

**Notes:** (1) E-TRM-\*\* terminators can be ordered separately - see tech table GS500

## 13 REMOTE PRESSURE TRANSDUCER CONNECTOR CHARACTERISTICS - to be ordered separately

CODE	ZH-4P-M8/5
Type	Male straight circular socket plug 4 pin
Standard	M8 – IEC 60947-5-2
Material	Plastic
Cable gland	Connector moulded on cable 5 m lenght
Cable	4x 0,25 mm <sup>2</sup>
Connection type	cable
Protection (EN 60529)	IP 67

## 14 OVERALL DIMENSIONS [mm]

