

Digital electronic TEB/LEB drivers

integral-to-valve format, for proportional valves with one or two spool position transducers

DKZOR-TEB-SN-NP

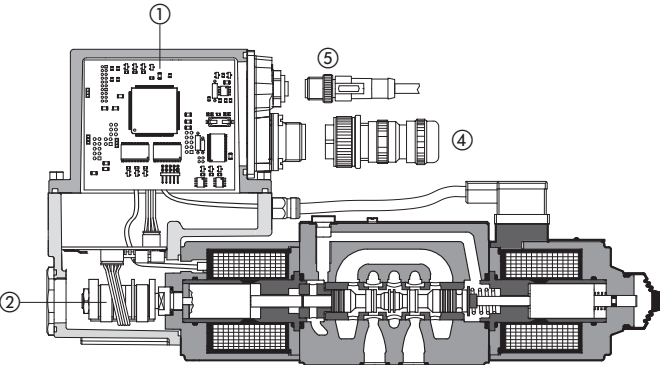
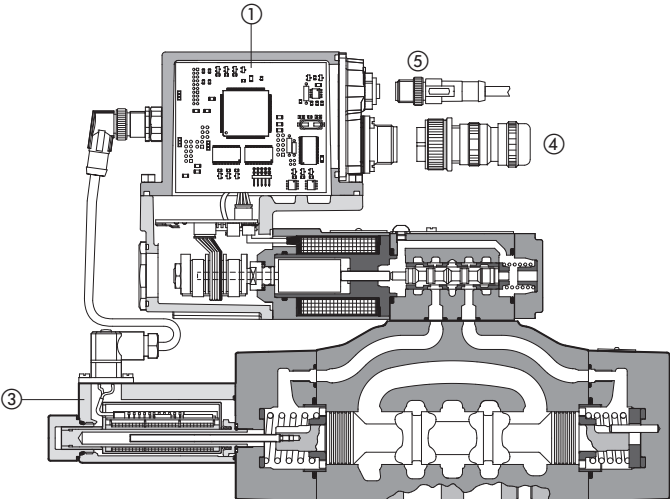

DPZO-LEB-SN-NP

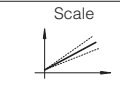

Scale

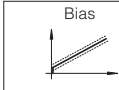

Bias

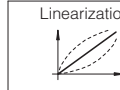

Linearization

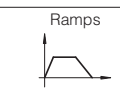

Ramps



Enhanced Diagnostic

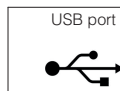

USB port

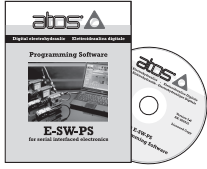

E-SW-PS
programming software

Connectors and cables ④ and ⑤ not included, to be ordered separately

TEB, LEB

Digital drivers ① supply and control, in closed loop, the position of the spool or poppet of direct and pilot operated proportional valves according to the electronic reference input signal.

TEB execution operates direct operated directional/flow control valves with one integral spool position transducer ②.

LEB execution operates pilot operated directional valves with two integral spool position transducers ② and ③.

Atos PC software allows to customize the driver configuration to the specific application requirements.

Electrical features:

- Functional parameters are factory preset for best performances
- 7 pin main connector ④ for power supply, analog input reference and monitor signals
- 5 pin USB connector ⑤ always present
- /Q option 7 pin main connector for enable signal
- /F option 7 pin main connector for fault signal
- /Z option 12 pin main connector for additional enable and fault signals
- Electrical protection against reverse polarity of power supply
- Operating temperature range: $-40^{\circ} \div +60^{\circ}$
- IP66 / IP67 protection degree
- Rugged construction
- CE mark according to EMC directive

Software Features:

- Intuitive graphic interface
- Setting of valve's functional parameters: bias, scale, ramps, dither
- Linearization function for the hydraulic regulation
- Setting of PID gains
- Selection of analog IN / OUT range
- Complete diagnostics of driver status
- Internal oscilloscope function
- In field firmware update through USB port

1 VALVES RANGE

Valves model	Directional			Flow	Directional	Cartridge
	DHZO DKZOR	DLHZO DLKZOR	DPZO	QVHZO QVKZOR	DPZO	LIQZO LIQZP
Data sheet	FS165, FS168	FS180	FS172	FS412	FS175, FS178	FS330, FS340
Driver model	TEB			LEB		

2 MAIN CHARACTERISTICS

Power supplies (see 4.1, 4.4)	Nominal : +24 V _{DC} Rectified and filtered : $V_{RMS} = 20 \div 32 V_{MAX}$ (ripple max 10 % V _{PP})
Max power consumption	50 W
Reference input signals (see 4.2)	Voltage: range ± 10 V _{DC} (24 V _{MAX} tollerant) Input impedance: R _i > 50 k Ω Current: range ± 20 mA Input impedance: R _i = 500 Ω
Monitor outputs (see 4.3)	Output range: voltage ± 10 V _{DC} @ max 5 mA current ± 20 mA @ max 500 Ω load resistance
Enable input (see 4.5)	Range: 0 \div 5 V _{DC} (OFF state), 9 \div 24 V _{DC} (ON state), 5 \div 9 V _{DC} (not accepted); Input impedance: R _i > 10 k Ω
Fault output (see 4.6)	Output range: 0 \div 24 V _{DC} (ON state > [power supply - 2 V] ; OFF state < 1 V) @ max 50 mA; external negative voltage not allowed (e.g. due to inductive loads)
Alarms	Solenoid not connected/short circuit, cable break with current reference signal, over/under temperature, valve spool transducer malfunctions
Format	Sealed box on the valve; IP66 / IP67 protection degree
Tropicalization	Tropical coating on electronics PCB
Operating temperature	-40 \div +60 °C (storage -40 \div +70 °C)
Mass	Approx. 490 g
Additional characteristics	Short circuit protection of solenoid's current supply; spool position control by P.I.D. with rapid solenoid switching; protection against reverse polarity of power supply
Electromagnetic compatibility (EMC)	According to Directive 2004/108/CE (Immunity: EN 61000-2; Emission: EN 61000-3)
Communication interface	USB - Atos ASCII coding
Communication physical layer	USB 2.0 + USB OTG - not insulated
Recommended wiring cable (see 9)	LiYCY shielded cables

Note: a minimum time of 300 to 500 ms have be considered between the driver energizing with the 24 V_{DC} power supply and when the valve is ready to operate. During this time the current to the valve coils is switched to zero

3 CONNECTIONS

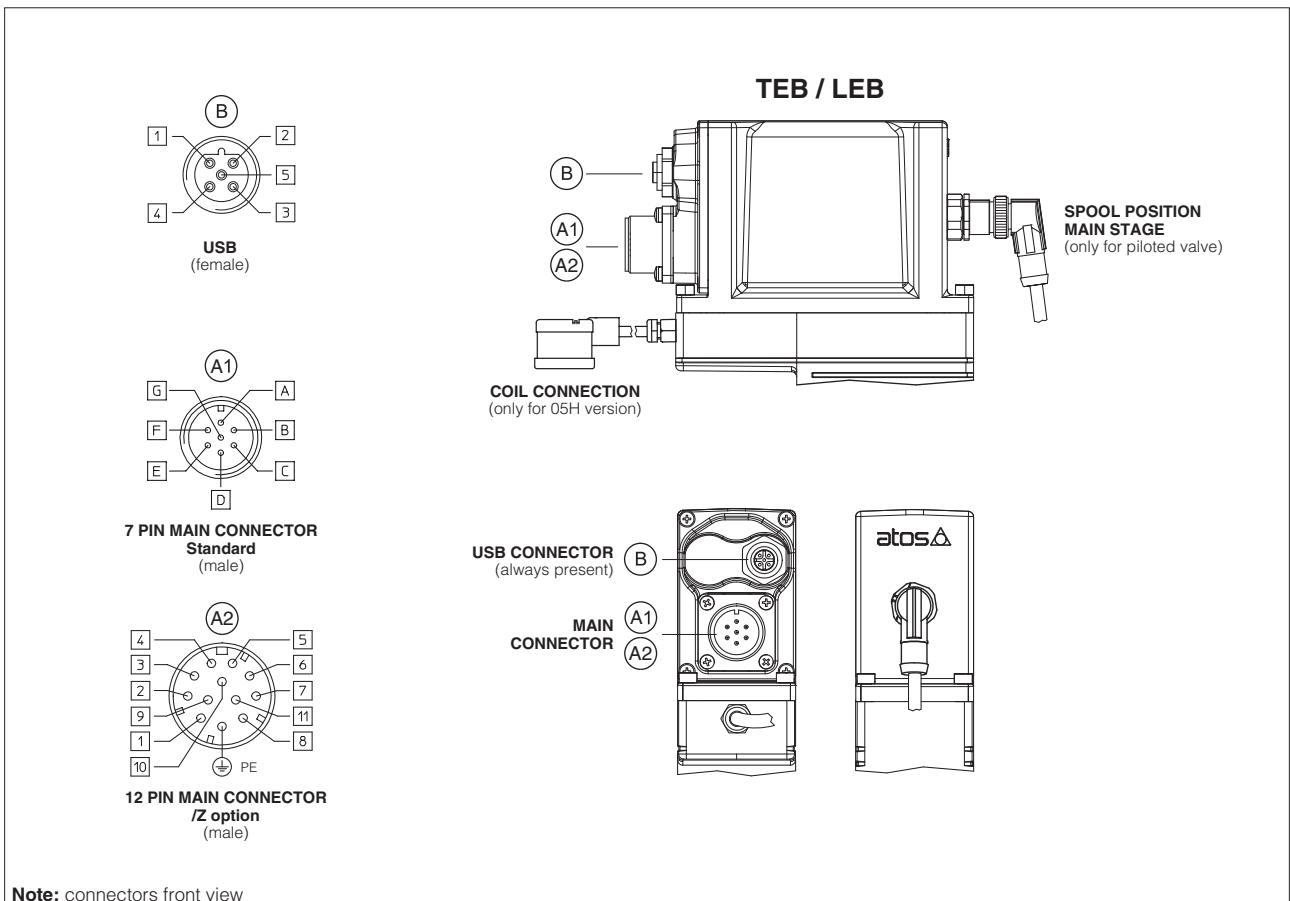

3.1 Main connector signals - 7 pin - standard, /Q and /F options (A1) - see 8.1

PIN	Standard	/Q	/F	TECHNICAL SPECIFICATIONS	NOTES
A	V+			Power supply 24 V _{dc} (see 4.1)	Input - power supply
B	V0			Power supply 0 V _{dc} (see 4.1)	Gnd - power supply
C	AGND		AGND	Analog ground	Gnd - analog signal
		ENABLE		Enable (24 V _{dc}) or disable (0 V _{dc}) the driver, referred to V0 (see 4.4)	Input - on/off signal
D	Q_INPUT+			Flow reference input signal: ±10 V _{dc} / ±20 mA maximum range (see 4.2)	Input - analog signal Software selectable
E	INPUT-			Negative reference input signal for Q_INPUT+	Input - analog signal
F	Q_MONITOR referred to: AGND V0			Flow monitor output signal: ±10 V _{dc} / ±20 mA maximum range (see 4.3)	Output - analog signal Software selectable
			FAULT	Fault (0 V _{dc}) or normal working (24 V _{dc}), referred to V0 (see 4.6)	Output - on/off signal
G	EARTH			Internally connected to driver housing	

3.2 Main connector signals - 12 pin - /Z option (A2) - see 8.2

PIN	/Z	TECHNICAL SPECIFICATIONS	NOTES
1	V+	Power supply 24 V _{dc} (see 4.1)	Input - power supply
2	V0	Power supply 0 V _{dc} (see 4.1)	Gnd - power supply
3	ENABLE	Enable (24 V _{dc}) or disable (0 V _{dc}) the driver, referred to V0 (see 4.4)	Input - on/off signal
4	Q_INPUT+	Flow reference input signal: ±10 V _{dc} / ±20 mA maximum range (see 4.2)	Input - analog signal Software selectable
5	INPUT-	Negative reference input signal for Q_INPUT+	Input - analog signal
6	Q_MONITOR	Flow monitor output signal: ±10 V _{dc} / ±20 mA maximum range, referred to AGND (see 4.3)	Output - analog signal Software selectable
7	AGND	Analog ground	Gnd - analog signal
8	R_ENABLE	Repeat enable, output repeater signal of enable input, referred to V0 (see 4.5)	Output - on/off signal
9	NC	Do not connect	
10	NC	Do not connect	
11	FAULT	Fault (0 V _{dc}) or normal working (24 V _{dc}), referred to V0 (see 4.6)	Output - on/off signal
PE	EARTH	Internally connected to driver housing	

3.3 USB connector - M12 - 5 pin (B) - always present

PIN	SIGNAL	TECHNICAL SPECIFICATION (1)
1	+5V_USB	Power supply
2	ID	Identification
3	GND_USB	Signal zero data line
4	D-	Data line -
5	D+	Data line +

Note: (1) shield connection on connector's housing is recommended

4 SIGNALS SPECIFICATIONS

Atos digital drivers are CE marked according to the applicable directives (e.g. Immunity/Emission EMC Directive).

Installation, wirings and start-up procedures must be performed according to the general prescriptions shown in tech table **F003** and in the user manuals included in the E-SW-PS programming software.

The electrical signals of the valve (e.g. monitor signals) must not be directly used to activate safety functions, like to switch-ON/OFF the machine's safety components, as prescribed by the European standards (Safety requirements of fluid technology systems and components-hydraulics, EN-982).

4.1 Power supply (V+ and V0)

The power supply must be appropriately stabilized or rectified and filtered: apply at least a 10000 μ F/40 V capacitance to single phase rectifiers or a 4700 μ F/40 V capacitance to three phase rectifiers.

A safety fuse is required in series to each driver power supply: 2,5 A fuse.

4.2 Flow reference input signal (Q_INPUT+)

The driver controls in closed loop the valve spool position proportionally to the external reference input signal.

Reference input signal is factory preset according to selected valve code, defaults are ± 10 Vdc for standard and $4 \div 20$ mA for /I option.

Input signal can be reconfigured via software selecting between voltage and current, within a maximum range of ± 10 Vdc or ± 20 mA.

4.3 Flow monitor output signal (Q_MONITOR)

The driver generates an analog output signal proportional to the actual spool position of the valve; the monitor output signal can be software set to show other signals available in the driver (e.g. analog reference, pilot spool position).

Monitor output signal is factory preset according to selected valve code, defaults are ± 10 Vdc for standard and $4 \div 20$ mA for /I option.

Output signal can be reconfigured via software selecting between voltage and current, within a maximum range of ± 10 Vdc or ± 20 mA.

4.4 Enable input signal (ENABLE) - only for /Q and /Z options

To enable the driver, supply a 24 Vdc on pin 3: Enable input signal allows to enable/disable the current supply to the solenoid, without removing the electrical power supply to the driver; it is used to active the communication and the other driver functions when the valve must be disabled for safety reasons. This condition does not comply with European Norms EN13849-1 (ex EN954-1).

4.5 Repeat enable output signal (R_ENABLE) - only for /Z option

Repeat enable is used as output repeater signal of enable input signal (see 4.4).

4.6 Fault output signal (FAULT) - only for /F and /Z options

Fault output signal indicates fault conditions of the driver (solenoid short circuits/not connected, reference signal cable broken for $4 \div 20$ mA input, spool position transducer cable broken, etc.). Fault presence corresponds to 0 Vdc, normal working corresponds to 24 Vdc.

Fault status is not affected by the Enable input signal.

5 PROGRAMMING TOOLS - see tech table GS500

Valve's functional parameters and configurations, can be easily set and optimized using Atos E-SW-PS programming software connected via USB communication port to the digital driver (see 5.1).

WARNING: drivers USB port is not isolated!

Use of E-A-SB-USB/OPT isolator adapter is highly recommended for PC protection.

5.1 - USB connection

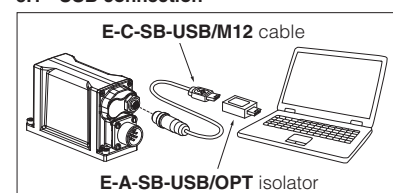

Basic programming software, free download :

E-SW-PS web download = software can be downloaded upon web registration at www.download.atos.com ; service and DVD not included

Upon web registration user receive via email the Activation Code (software free license) and login data to access Atos Download Area.

The software remains active for 10 days from the installation date and then it stops until the user inputs the Activation Code.

Full programming software, to be ordered separately :

E-SW-PS DVD first supply = software has to be activated via web registration at www.download.atos.com ; 1 year service included

Upon web registration user receive via email the Activation Code (software license) and login data to access personal Atos Download Area.

The software remains active for 10 days from the installation date and then it stops until the user inputs the Activation Code.

E-SW-PS-N DVD next supplies = only for supplies after the first; service not included, web registration not allowed

Software has to be activated with Activation Code received upon first supply web registration

Atos Download Area: direct access to latest releases of E-SW-PS software, manuals, USB drivers and fieldbus configuration files at www.download.atos.com

USB Adapters and Cables, can be ordered separately

6 MAIN SOFTWARE PARAMETER SETTINGS

The following is a brief description of the main settings and features of digital drivers.

For a detailed descriptions of available settings, wirings and installation procedures, please refer to the user manual included in the E-SW-PS DVD programming software:

E-MAN-RI-LEB - user manual for TEB and LEB

6.1 Scale

Scale function allows to set the maximum valve opening at maximum reference signal value.

This regulation allows to reduce the maximum valve regulation in front of maximum reference signal.

Two different Scale regulations are available for double solenoid valves or three position single solenoid valves: ScaleA for positive and ScaleB for negative reference signal.

6.2 Bias and Threshold

Proportional valves may be provided with a dead band in the hydraulic regulation corresponding to their switch-off status.

This dead band discontinuity in the valve's regulation can be compensated by activating the Bias function, which adds a fixed preset Bias value to the reference signal (analog external input).

The Bias function is activated when the reference signal overcome the Threshold value, preset into the driver.

The Bias setting allows to calibrate the Bias valve opening to the specific proportional valve to which the driver is coupled.

The Threshold setting is useful to avoid undesired valve regulation at zero reference signal when electric noise is present on the analog input signal: smaller threshold reduces the reference signal dead band, greater values are less affected by electric noise presence.

Two different Bias regulations are available for double solenoid valves: positive reference signals activate BiasA and negative reference signals activate BiasB.

Refer to the programming manuals for a detailed description of other software selectable Bias functions.

6.3 Offset

Proportional valves may be provided with zero overlapping in the hydraulic regulation corresponding to zero reference input signal (valve's central spool position).

The Offset function allows to calibrate the valve's spool central position to the specific hydraulic system setup (e.g. valve applied to cylinder with differential areas). Offset default setting is zero.

6.4 Ramps

The ramp generator allows to convert sudden change of electronic reference signal into smooth time-dependent increasing/decreasing of the valve opening.

Different ramp mode can be set:

- single ramp for any reference variation
- two ramps for increasing and for decreasing reference variations
- four ramps for positive/negative signal values and increasing/decreasing reference variations

Ramp generator is useful for application where smooth hydraulic actuation is necessary to avoid machine vibration and shocks.

If the proportional valve is driven by a closed loop driver, the ramps can lead to unstable behaviour, for these applications ramp function can be software disabled (default setting).

6.5 Linearization

Linearization function allows to set the relation between the reference input signal and the controlled valve's regulation.

Linearization is useful for applications where it is required to linearize the valve's regulation in a defined working condition.

6.6 Dither

The dither is an high frequency modulation added to the valve's reference signal to reduce the hysteresis of the valve's regulation; in fact a small vibration in the valve's hydraulic regulation considerably reduces the mechanical friction effects (e.g. due to cylinder seals).

Dither frequency and amplitude are software selectable; the amplitude is automatically reduced at high reference values (high regulated flow / cylinder speed) to avoid possible instability.

Lower frequency and higher amplitude reduce hysteresis but also reduce the regulation stability. In some application this can lead to vibration and noise: right setting usually depends on system setup.

Dither default setting is disabled.

6.1, 6.2 - Scale, Bias & Threshold

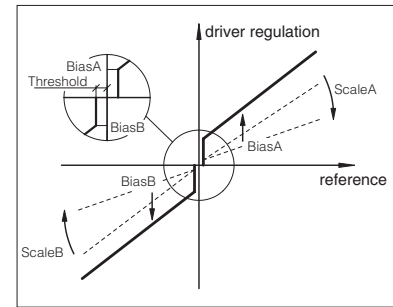

6.3 - Offset

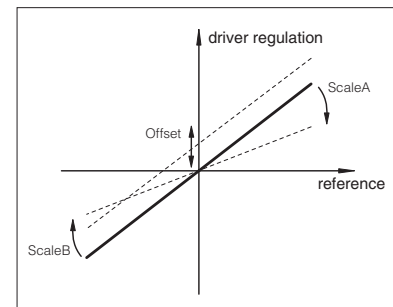

6.4 - Ramps

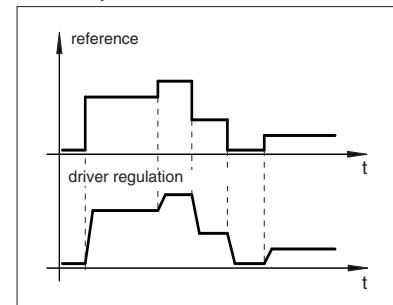

6.5 - Linearization

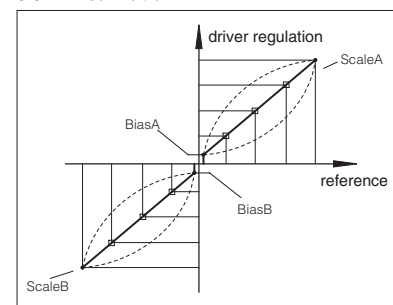

7 OVERALL DIMENSIONS [mm]

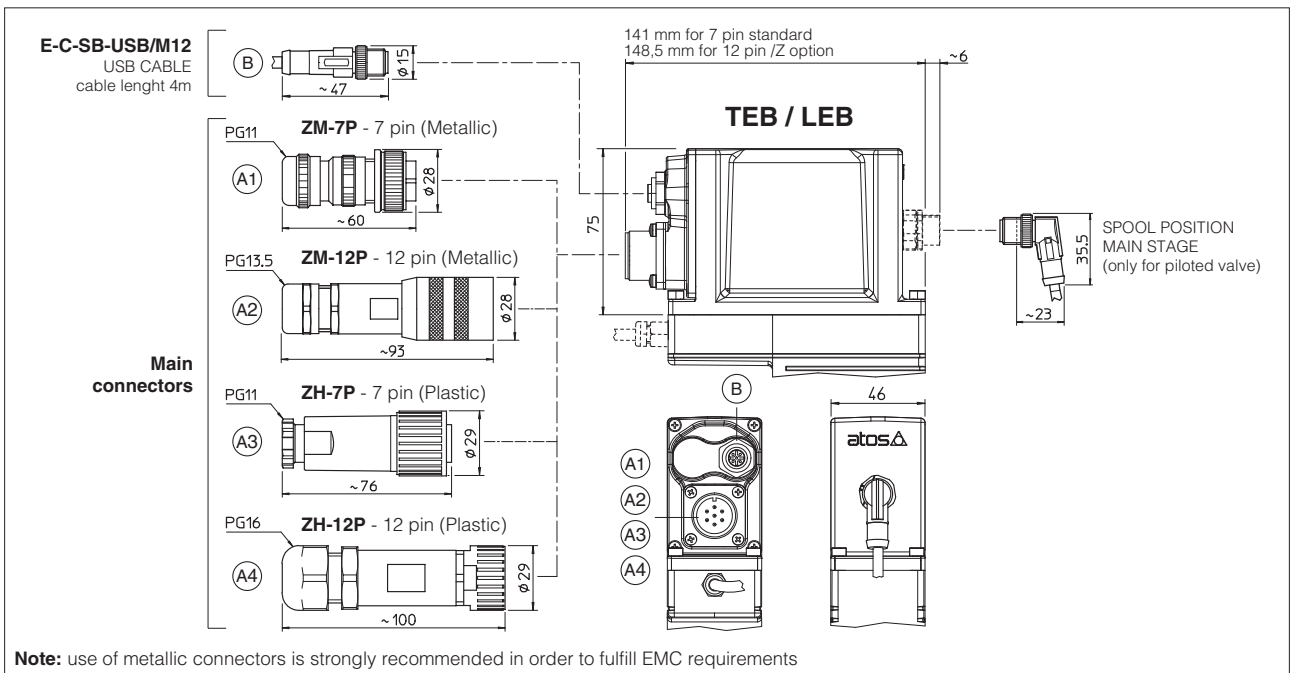

8 CONNECTORS CHARACTERISTICS - to be ordered separately

8.1 Main connectors - 7 pin

CONNECTOR TYPE	POWER SUPPLY	POWER SUPPLY
CODE	(A1) ZM-7P	(A3) ZH-7P
Type	7pin female straight circular	7pin female straight circular
Standard	According to MIL-C-5015	According to MIL-C-5015
Material	Metallic	Plastic reinforced with fiber glass
Cable gland	PG11	PG11
Recommended cable	LiYCY 7 x 0,75 mm ² max 20 m (logic and power supply) or LiYCY 7 x 1 mm ² max 40 m (logic and power supply)	LiYCY 7 x 0,75 mm ² max 20 m (logic and power supply) or LiYCY 7 x 1 mm ² max 40 m (logic and power supply)
Conductor size	up to 1 mm ² - available for 7 wires	up to 1 mm ² - available for 7 wires
Connection type	to solder	to solder
Protection (EN 60529)	IP 67	IP 67

8.2 Main connectors - 12 pin

CONNECTOR TYPE	POWER SUPPLY	POWER SUPPLY
CODE	(A2) ZM-12P	(A4) ZH-12P
Type	12pin female straight circular	12pin female straight circular
Standard	DIN 43651	DIN 43651
Material	Metallic	Plastic reinforced with fiber glass
Cable gland	PG13,5	PG16
Recommended cable	LiYCY 12 x 0,75 mm ² max 20 m (logic and power supply)	LiYCY 10 x 0,14mm ² max 40 m (logic) LiYY 3 x 1mm ² max 40 m (power supply)
Conductor size	0,5 mm ² to 1,5 mm ² - available for 12 wires	0,14 mm ² to 0,5 mm ² - available for 9 wires 0,5 mm ² to 1,5 mm ² - available for 3 wires
Connection type	to crimp	to crimp
Protection (EN 60529)	IP 67	IP 67

9 MODEL CODE FOR SPARE PARTS

Integral drivers are available as spare parts only for Atos authorized service centers.

E-RI	-	T	-	EB	-	N	-	NP	-	01H	/	P	/	*	/	*
Integral electronic driver																
<p>T = closed-loop one LVDT transducer L = closed-loop two LVDT transducers</p> <p>EB = basic</p> <p>Options, see section 3: F = fault signal Q = enable signal Z = enable, fault and monitor signals (12 pin connector)</p> <p>P = for pilot operated proportional valves (only for TEB)</p> <p>01H = for single solenoid proportional valves 05H = for double solenoid proportional valves (only for TEB)</p> <p>Fieldbus interface. USB port always present: NP = Not Present</p> <p>(1) set code identifies the correspondence between the integral driver and the relevant valve; it is assigned by Atos when the driver is ordered as spare part</p>																
Set code (1)																
Series number																